

**Please read and save these instructions. Read carefully before attempting to assemble, install, operate or maintain the product described.**

**Protect yourself and others by observing all safety information. Failure to comply with instructions could result in personal injury and / or property damage! Retain instructions for future reference.**

# WELTEM ICEN

## Portable Dehumidifier

### Description

WELTEM Dehumidifier is suitable for areas/places where humidity causes serious problems.

Strong dehumidification performance can prevent any issues resulted from humidity. Auto drain pump is equipped in the unit so it is very convenient for user. A control panel provides ease of use and contains a self-diagnostic function and display, showing operating modes, current humidity and target humidity, and faults.

If an abnormal operation occurs, a visual display of the fault is shown. Caster wheels are included for easy portability. Suitable applications include: a factory or work place, industrial kitchen, computer room, emergency cooling, outdoor event, etc.



**WPD-120**  
**Figure 1**

### Unpacking

After unpacking the unit, carefully inspect unit for any damage that may have occurred during transit. Check for any loose, missing, or damaged parts.

### Specifications

Model No.	Power Supply Ph-V-Hz	Dehumidification Amount	Power Consumption Watts	Rated Current Amps
WPD-120	Single Phase, 230V, 50Hz	120L/1day	920	4.42
Model No.	Nema Plug	Power Cord Gauge AWG	Power Cord Length ft	Dimensions W x D x H - in. (mm)
WPD-120	5-15P	14	10	21.7x 23.9 x 33 (551 x 607 x 839)
Model No.	Weight (Net / Gross) Lbs(kg)	Supply air Flow (CMH)	Ambient temperature range °F( °C)	
WPD-120	141 / 152 lbs.(64/ 69kg)	828	59~95(15~35)	

## Specifications (Continued)

Model No.	Target humidity range	Setting range	
WPD-120	0 ~ 99 %	20 ~ 80 %	

Model No.	Refrigerant Type / oz(g)	Wheels pcs / diameter	Design Pressure - Hi/Low Psig
WPD-120	R-410A / 35.3(1000)	4 / 76mm	450 / 250

Safety Devices	Compressor overload protector, Anti-freezing thermostat, Full drain tank switch, Automatic restart (Power interruption), Compressor time delay program, High pressure switch
Features	Temperature control, Self-diagnostic function, Two speed fan, Optional drain pump kit, Washable filters, °F( °C) display, Off-timer

## General Safety Information

Please read this manual carefully for instructions on correct installation and usage. Please read all safeguards.

1. Transport and store the unit in an upright position only. Leave unit in an upright position for at least 3 hours before first use.
2. Always place the unit on an even, level surface.
3. Ensure the unit is connected to a grounded power supply of the correct rating / capacity.
4. The unit is designed to operate under 15°C (59°F)~35°C (95°F) and RH maximum 80%.
5. DO NOT use this unit for functions other than those described in this instruction manual.
6. DO NOT tilt the unit.
7. DO NOT cover or obstruct the unit's inlet and outlet grilles.
8. DO NOT use the unit in areas where it will be exposed to rain or water.
9. NEVER unplug the unit while it is operating.

**▲ WARNING**

***DO NOT use the unit in wet environments, such as a laundry room, to avoid the risk of electrical shock.***

10. DO NOT place any foreign objects on the unit.
11. DO NOT operate the unit with wet or damp hands.
12. DO NOT allow chemical substances to come into contact with the unit.
13. DO NOT operate the unit in the presence of flammable substances or vapors such as alcohols, pesticides, gasoline, etc.

**▲ WARNING** *DO NOT operate the unit in explosive or flammable environments.*

14. DO NOT use the plug to start and to stop the unit. Always use the control panel to start and to stop the unit.
15. Always turn off the unit when it is not in use and unplug the power plug from the electrical outlet.
16. Always turn the unit off and unplug the main power plug from the electrical outlet before cleaning, moving or performing maintenance.
17. AVOID the use of adapter plugs or extension cords. If it is necessary to use an extension cord or an adapter plug to operate the unit, ensure that they are correctly rated for the application. Consult a local qualified electrician and all local electrical codes to ensure proper setup. Any extension cord used with this device must be rated for a minimum of 15A.(230V)
18. DO NOT unplug the unit by pulling on the electrical cord. Keep electrical cord away from heat sources and always completely unroll the cord to avoid overheating. If the power cord becomes damaged, a qualified service agent, qualified electrician, or similarly qualified person must replace it, in order to avoid a hazard or shock.

**▲ WARNING** *DO NOT operate a unit with a damaged power cord.*

19. The filters must be used with the product at all times. When the filters are removed for cleaning, always ensure that the unit has been turned off and unplugged from the electrical outlet.
20. Regularly clean the filters to maintain efficiency. If the filters are not cleaned regularly, the units output performance and efficiency will decline and energy consumption will increase.
21. DO NOT operate the unit with a damaged power cord or plug, after it malfunctions, has been dropped or damaged.
22. Only use in the upright position on an even, flat surface. Unit must be positioned at least 24 inches (60 cm) from the nearest object in any direction.
23. Stop operation immediately if abnormal noise or odor is noticed. Contact a local service center.
24. Appliance is not to be used by children or persons with reduced physical, sensory or mental capabilities, or lack of experience and knowledge, unless they have been given supervision or instruction.
25. Children being supervised not to play with appliance.
26. That the appliance shall be installed in accordance with national wiring regulations.
27. If the supply cord is damaged, it must be replaced by the manufacturer, its service agent or similarly qualified persons in order to avoid a hazard.

**SAVE THESE INSTRUCTIONS**

## Assembly (WPD-120)

### Front View

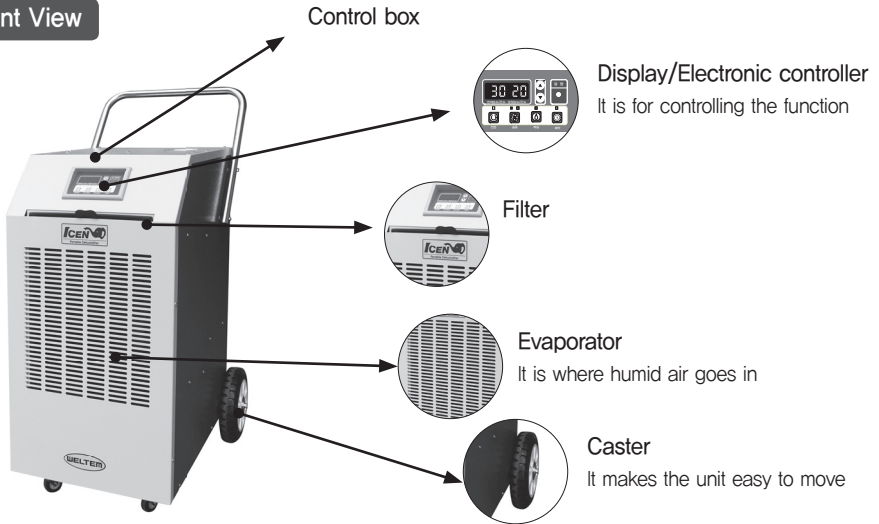

Figure 2

### Rear View

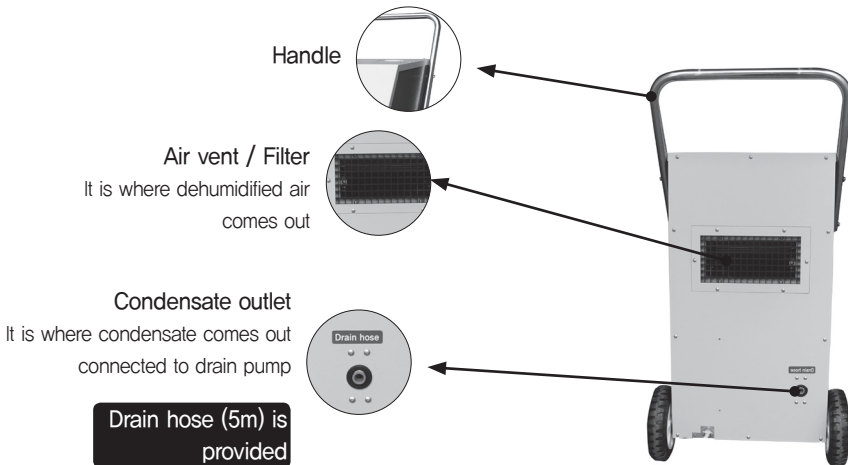

Figure 3

## Installation

### WARNINGS REGARDING PROPER LOCATION FOR INSTALLATION

- ▲ WARNING** *Do not use the unit in explosive environments or in areas where flammable gas leakage may occur.*
- ▲ WARNING** *Do not use the unit in areas where it will be exposed to rain or water.*
- ▲ WARNING** *Do not use the unit in a corrosive atmosphere.*
- ▲ WARNING** *Do not use the unit above 5°C(41°F) ~ 35°C(95°F).*
- ▲ WARNING** *Do not install the unit on uneven or sloping surface. The unit may roll or topple over even if the casters are set to the locked position.*

## MOVING THE UNIT

Unlock the casters and push the unit using the side handles to a flat, level surface and set the caster brakes to the locked position.

## PLUGGING IN THE UNIT

Check the prongs and surface of the power cord plug for dust/dirt. If dust and/or dirt are present, wipe off with a clean, dry cloth.

Check the power cord, plug and prongs for damage or excess play.

If any damage or excess play is found, contact a qualified repair technician or a qualified electrician to perform replacement or repair of the power cord, plug or prongs.

- ▲ WARNING** *If the power cord or plug is damaged, repair should only be performed by qualified electrical personnel.*
- ▲ WARNING** *Do not connect / disconnect the power cord or attempt to operate buttons with wet hands. This could result in electrical shock.*

**NOTE:** Make sure the air vent is free of dirt, dust, oil, water, or any other foreign material.

The unit is equipped with an approved NEMA plug configuration. (WPD-120: 5-15P)

The appropriate outlet must be used for each plug type.

## Operation

### CONTROL PANEL

(1) Display panel for Icen dehumidifier

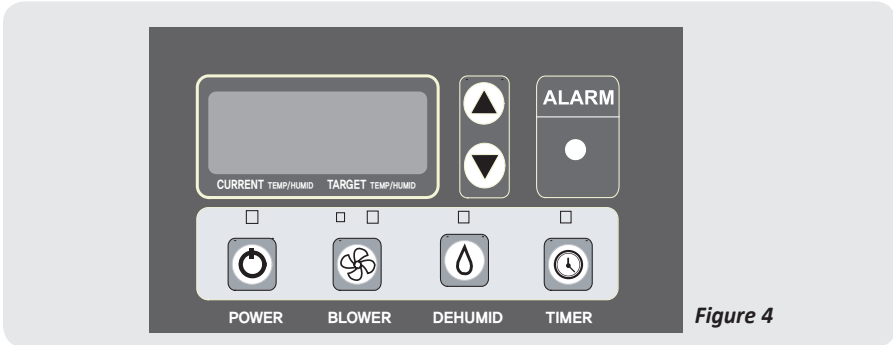













Figure 4

(2) Description of display panel for Icen dehumidifier

<p>POWER BUTTON</p>	<p>1) Power is supplied with deeping sound and fan starts to work when power button is pushed. (Fan starts from Low speed)</p> <p>2) The unit restarts automotically in the case of short-term blackout</p>
<p>BLOWER BUTTON</p>	<p>1) It works on dehumidification and blower mode</p> <p>2) <input checked="" type="checkbox"/> <input type="checkbox"/> Low, <input type="checkbox"/> <input checked="" type="checkbox"/> High, <input checked="" type="checkbox"/> <input checked="" type="checkbox"/> Auto It is implemented in Low, High and Auto order and needs switching time</p> <p>3) When the gap between current temperature and target humidit is over 15%, High-mode works. When less than 15%, Low-mode works</p>
<p>HUMIDITY BUTTON</p>	<p>1) Dehumidification mode works after pressing the dehumidification button for a second</p> <ul style="list-style-type: none"> <li>- Lamp on display is turned on during dehumidification mode whereas it is turned off when it is not on dehumidification mode</li> <li>- It is controlled based on dehumidification sensor and relative humidity is displayed</li> </ul> <p>2) Humidity measured on display: 0~99%</p> <p>3) Setting range: 20~80%  Setting range is controlled by 'UP' and  'DOWN' button (It is either increased or decreased by 5%)</p>

(2) Description of display panel for Icen dehumidifier

 <p>TIMER BUTTON</p>	<p>1) Time is set by pressing the TIMER button for a second</p> <ul style="list-style-type: none"> <li>- If user do not press any buttons for 5 seconds, it returns to original mode by pressing dehumidification button  or selecting set time</li> <li>- During setting mode, user controls setting range by pressing the 'UP' and 'DOWN' button.</li> </ul> <p> (Setting range: 0~12 hrs, it is either increased or decreased by 30mins)</p> <p></p> <p>2) How to cancel TIMER function</p> <ul style="list-style-type: none"> <li>- Press the 'Power on/off' button or reset selected time </li> </ul> <p>3) The content displayed during TIMER function (Current humidity, Target humidity)  are displayed for 5 seconds and time left is displayed for 2 seconds </p>
<p>Current humidity, Setup humidity TEMP</p>	 <p>1) Current humidity and Target humidity are displayed</p> <p>2) How to see temperature: Press the blower and dehumidification button at the same time for a second then inlet and outlet temperature are displayed. The measurement returns from temperature to humidity in 5 seconds ( +  )</p>
<p>ALARM Lamp</p>	 <p>Operates(blinks) when abnormality occurs. System operation stops when it blinks longer than 3 minutes. When cancelled within 3 minutes, system</p>

## Maintenance

### FILTER CLEANING (See Figures 5 and 6)

Dehumidifier WPD-120 has 2 filters,

- 1) Open the front grill
- 2) Slide filter up and use a vacuum cleaner to remove the dust from the filter
- 3) If the filter is heavily covered with dust and dirt, warm water and mild soap or neutral detergent may be used to wash the filter

**Do not use any other chemicals to clean filter, as they will likely damage the filter.**

- 4) Dry the filter in a shaded area before replacing it. Do not operate the unit without the filter installed and the filter guard in the closed position
- 5) Replace the clean filter and close the filter grill

**Note :** For effective dehumidification, clean the filter at least every 2 weeks.

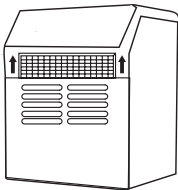

**Figure 5 – Removing Filters**

- To remove front filter pulling up filter frame,
- Slide filter up and use a vacuum cleaner to remove the dust from the filter.

- Remove dust from the filter using a vacuum cleaner hose attachment,
- if required wash the filter in lukewarm water with a mild detergent,  
Leave to dry in shaded area before reinstalling.

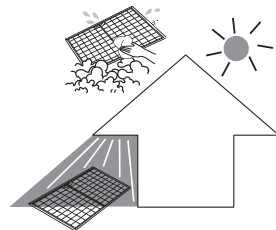

**Figure 6 – Removal of Dust**





## Maintenance *(Continued)*

– To ensure your product is covered by warranty, the complete faulty product along with your original purchase receipt must be provided at the place of purchase.

<b>Product</b>	<b>Portable Dehumidifier</b>
Model No.	_____
Date of Purchase	_____
Place of Purchase	_____
Serial No.	_____
Period of Warranty	_____

**Customer:** Please read and keep this manual for future reference and keep sales receipt as proof of purchase.

### SELF-DIAGNOSTIC CODES *(See Table 1)*

The alarm light is activated if abnormal operation occurs, and a code is displayed on the control panel. The compressor and condenser fan motor will stop operating. The evaporator fan will continue to run for 3 minutes. If the fault is rectified within 3 minutes, the unit will resume operation. If the fault persists for more than 3 minutes, the evaporator fan also stops. The fault must be rectified before the unit can resume normal operation.

**SELF-DIAGNOSTIC ALARM CODES**







Alarm Display	Problem	Cause	Corrective Action
	Frost prevention sensor	Indoor heat exchanger temperature too low	Do not use the machine if ambient temperature is lower than 18°C
	Refrigerant high pressure switch	<ul style="list-style-type: none"> <li>● Blocked air filter</li> <li>● Ambient temperature is too high</li> </ul>	<ul style="list-style-type: none"> <li>● Clean air filter</li> <li>● Do not sue the air conditioner if ambient temperature is higher than 45°C</li> </ul>
	Abnormal temperature sensor value	TH3 temperature sensor has a loose or broken connection	Contact a qualified service agent
	Compressor overloaded	<ul style="list-style-type: none"> <li>● Ambient temperature is too high</li> <li>● Unstable voltage supply</li> <li>● Defective compressor</li> <li>● Over current relay defect or broken connection</li> </ul>	<ul style="list-style-type: none"> <li>● Do not use the air conditioner if ambient temperature is higher than 45°C</li> <li>● Contact a qualified service agent</li> <li>● Replace compressor</li> </ul>
	Abnormal dehumidification sensor value	TH4(dehumidification) sensor has a loose or broken connection	Contact a qualified service agent
	Drain pump alarm	Drain pump defective or improper hose connection (including kink or blockage)	<ul style="list-style-type: none"> <li>● Contact a qualified service agent</li> <li>● Check the hose connection and hose</li> <li>● Replace drain pump</li> </ul>

Table 1- Alarm Codes

# Wiring Diagram

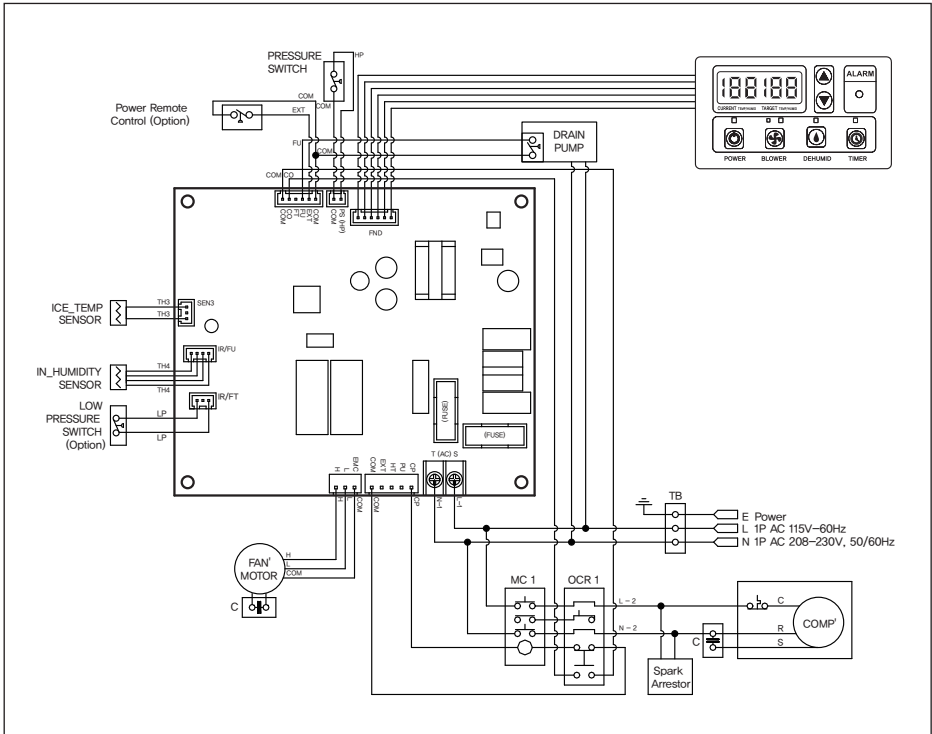

Figure 7 - Circuit Wiring Diagram (WPD-120)

**LIMITED WARRANTY**

**WELTEM ONE-YEAR LIMITED WARRANTY.** WELTEM PORTABLE AIR CONDITIONERS, MODELS COVERED IN THIS MANUAL, ARE WARRANTED BY WELTEM TO THE ORIGINAL USER AGAINST DEFECTS IN WORKMANSHIP OR MATERIALS UNDER NORMAL USE FOR ONE YEAR AFTER DATE OF PURCHASE. ANY PART WHICH IS DETERMINED TO BE DEFECTIVE IN MATERIAL OR WORKMANSHIP AND RETURNED TO AN AUTHORIZED SERVICE LOCATION, WELTEM DESIGNATES, SHIPPING COSTS PREPAID, WILL BE, AS THE EXCLUSIVE REMEDY, REPAIRED OR REPLACED BY WELTEM OPTION. FOR LIMITED WARRANTY CLAIM PROCEDURES, SEE "PROMPT DISPOSITION" BELOW. THIS LIMITED WARRANTY GIVE PURCHASERS SPECIFIC LEGAL RIGHTS WHICH VARY FROM JURISDICTION TO JURISDICTION.

**LIMITATION OF LIABILITY.** TO THE EXTENT ALLOWABLE UNDER APPLICABLE LAW, WELTEM LIABILITY FOR CONSEQUENTIAL AND INCIDENTAL DAMAGES IS EXPRESSLY DISCLAIMED. WELTEM LIABILITY IN ALL EVENTS IS LIMITED TO AND SHALL NOT EXCEED THE PURCHASE PRICE PAID.

**WARRANTY DISCLAIMER.** A DILIGENT EFFORT HAS BEEN MADE TO PROVIDE PRODUCT INFORMATION AND ILLUSTRATE THE PRODUCTS IN THIS LITERATURE ACCURATELY; HOWEVER, SUCH INFORMATION AND ILLUSTRATIONS ARE FOR THE SOLE PURPOSE OF IDENTIFICATION, AND DO NOT EXPRESS OR IMPLY A WARRANTY THAT THE PRODUCTS ARE MERCHANTABLE, OR FIT FOR PARTICULAR PURPOSE, OR THAT THE PRODUCTS WILL NECESSARILY CONFORM TO THE ILLUSTRATIONS OR DESCRIPTIONS. EXCEPT AS PROVIDED BELOW, NO WARRANTY OF AFFIRMATION OF FACT, EXPRESSED OR IMPLIED, OTHER THAN AS STATED IN THE "LIMITED WARRANTY" ABOVE IS MADE OR AUTHORIZED BY WELTEM.

**Technical Advice and Recommendations, Disclaimer.** Notwithstanding any past practice or dealings or trade custom, sales shall not include the furnishing of technical advice or assistance or system design. Weltem assumes no obligations or liability on account of any unauthorized recommendations, opinions or advice as to the choice, installation or use of products.

**Product Suitability.** Many jurisdictions have codes and regulations governing sales, construction, installation, and/or use of products for certain purposes, which may vary from those in neighboring areas. While attempts are made to assure that Weltem products comply with such codes, Weltem cannot guarantee compliance, and cannot be responsible for how the product is installed or used. Before purchase and use of a product, review the product applications, and all applicable national and local codes and regulations, and be sure that the product, installation, and use will comply with them.

Certain aspects of disclaimers are not applicable to consumer products; e.g., (a) some jurisdictions do not allow the exclusion or limitation of incidental or consequential damages, so the above limitation or exclusion may not apply to you; (b) also, some jurisdictions do not allow a limitation on how long an implied warranty lasts, consequently the above limitation may not apply to you; and (c) by law, during the period of this Limited Warranty, any implied warranties of implied merchantability or fitness for a particular purpose applicable to consumer products purchased by consumers, may not be excluded or otherwise disclaimed.

**Prompt Disposition.** A good faith effort will be made for prompt correction or other adjustment with the respect to any product which proves to be defective within limited warranty. For any product believed to be defective within limited warranty, first write or call dealer from whom the product was purchased. Dealer will give additional directions. If unable to resolve satisfactorily, write to Weltem at the address below, giving dealer's name, address, date, and number of dealer's invoice, and describing the nature of the defect. Title and risk of loss pass to buyer on delivery to common carrier. If product was damaged in transit to you, file claim with carrier.

Manufactured in Weltem co., Ltd., 154, Jayumuyeok 3-gil, Masanhoewon-gu, Changwon-City,  
Gyeongsangnam-do, 51340 Korea [www.weltem.com](http://www.weltem.com)

Printed in March, 2023